

Table of contents.....01

Drive components..... 02

Rubber roller lever, winch and switch.....03

Blade and deflector.....04

Roller and blade..... 05

Screens..... 06

Screens specifications.....07

Side deck.....08

Access door since March, 2014.....09

Access door before March, 2014.....10

Drain.....11

Intake.....12

6" cast iron gate valve.....13

Flow regulator.....14

<b>Hardware Identification</b>	
Type	Designation
Hexagonal bolt	-
Carriage bolt	CB
Square head bolt	SB
Socket head cap screw	SCS
Socket head set screw	SSS
Flat head cap screw	FCS
Hexagon nut	-
Hexagon nylon lock nut	N
Hexagon oval lock nut	OVL
Hexagon tri-lock nut	TRI
Castle nut	CSL
Flange nut	FLN
Wing nut	WNG
Flat washer	-
Lock washer	L
SAE washer	SAE
Large ext. dia. washer	LD
Small ext. dia. washer	SD
Stainless steel bolts parts	SS

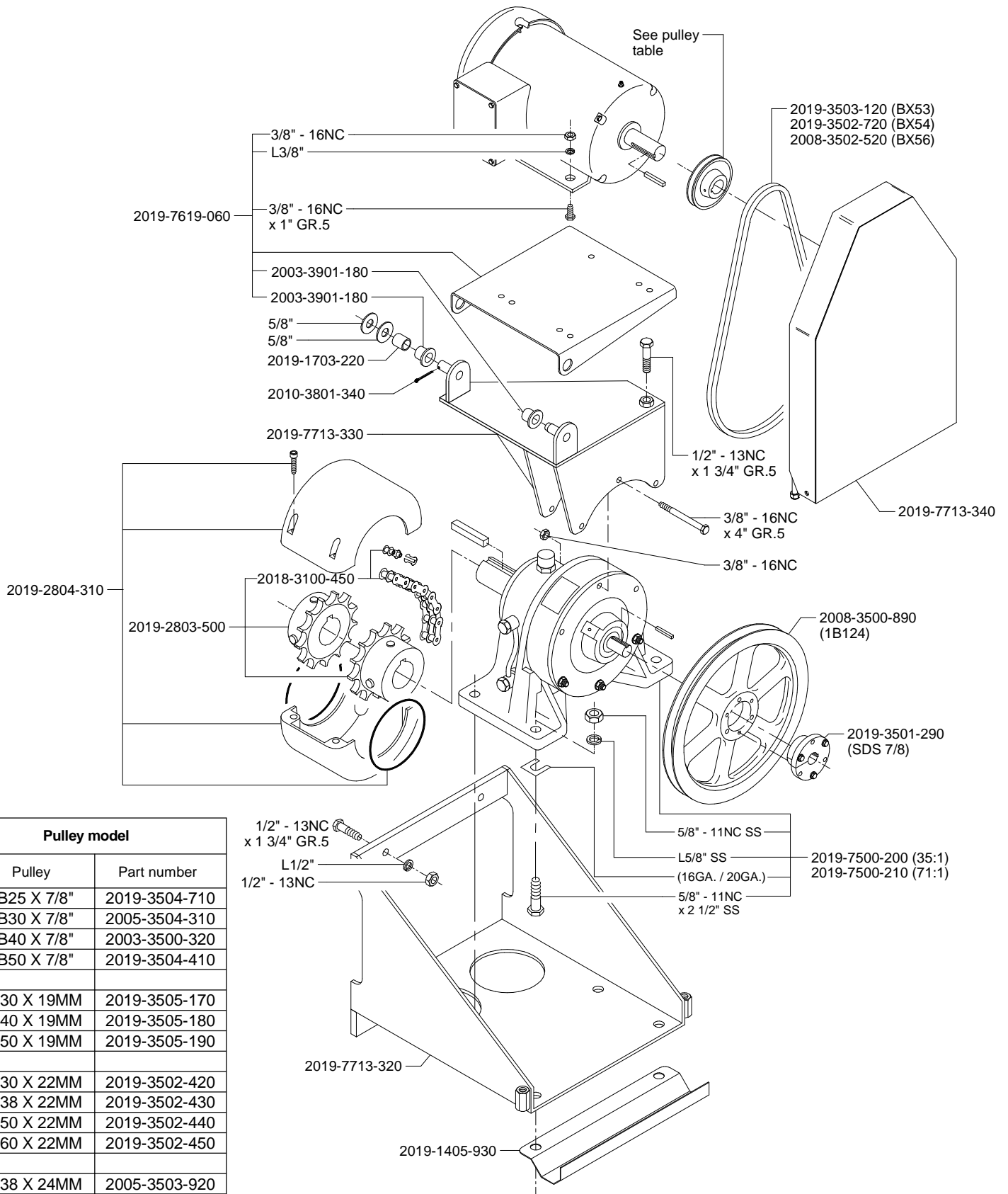

Pulley model	
Pulley	Part number
MB25 X 7/8"	2019-3504-710
MB30 X 7/8"	2005-3504-310
MB40 X 7/8"	2003-3500-320
MB50 X 7/8"	2019-3504-410
MB30 X 19MM	2019-3505-170
MB40 X 19MM	2019-3505-180
MB50 X 19MM	2019-3505-190
MB30 X 22MM	2019-3502-420
MB38 X 22MM	2019-3502-430
MB50 X 22MM	2019-3502-440
MB60 X 22MM	2019-3502-450
MB38 X 24MM	2005-3503-920
MB50 X 24MM	2019-3505-000
MB60 X 24MM	2019-3505-019

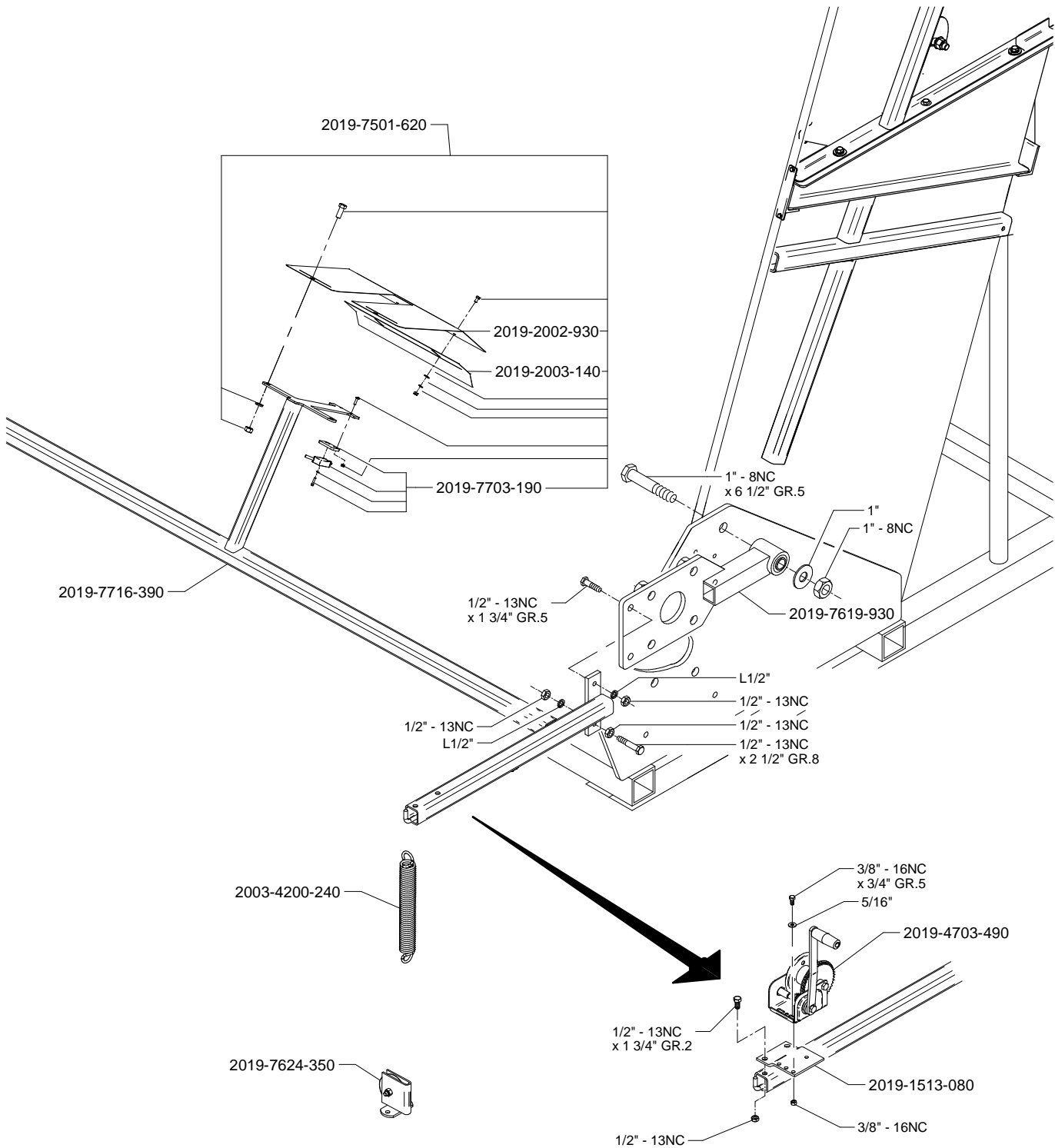

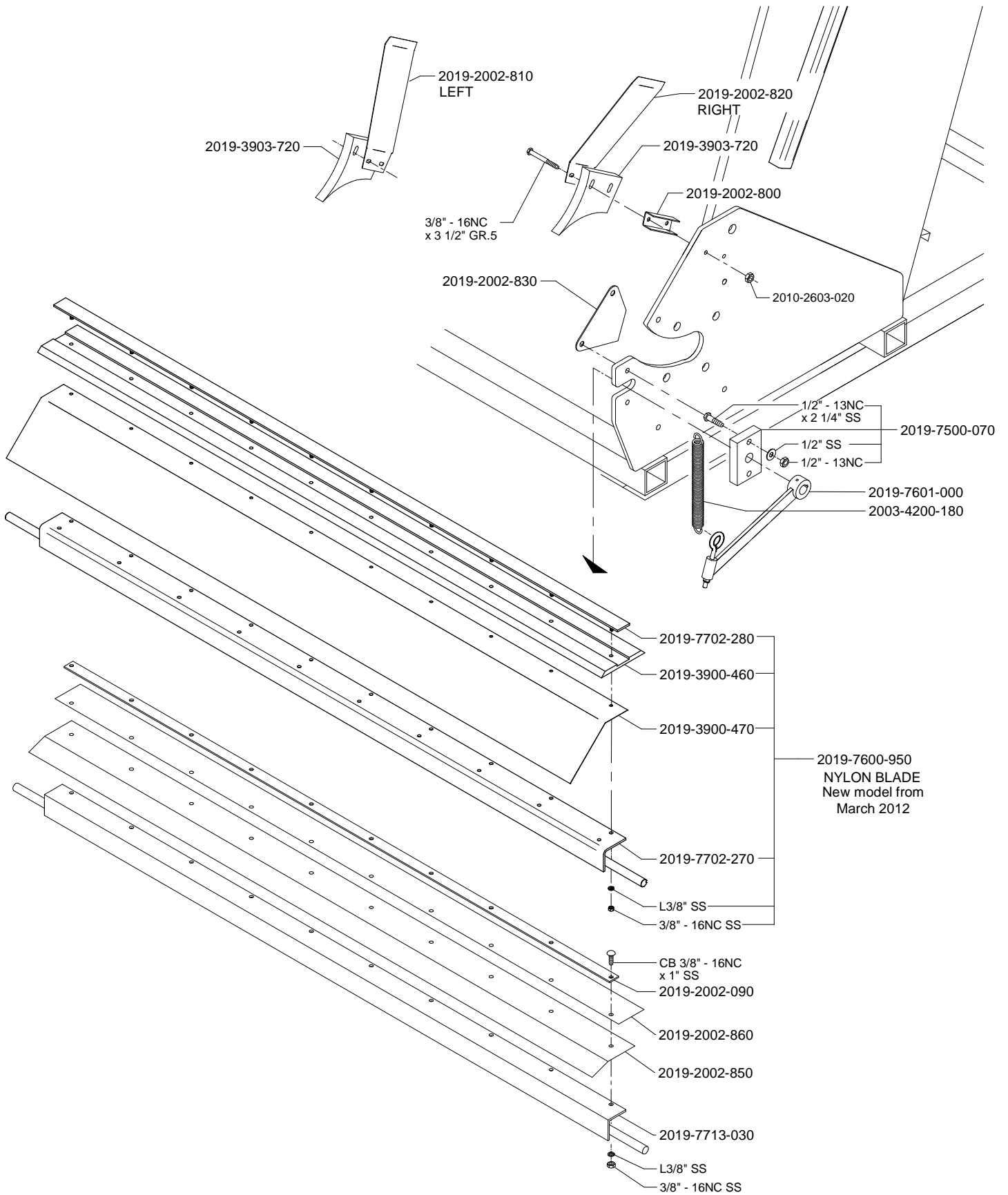



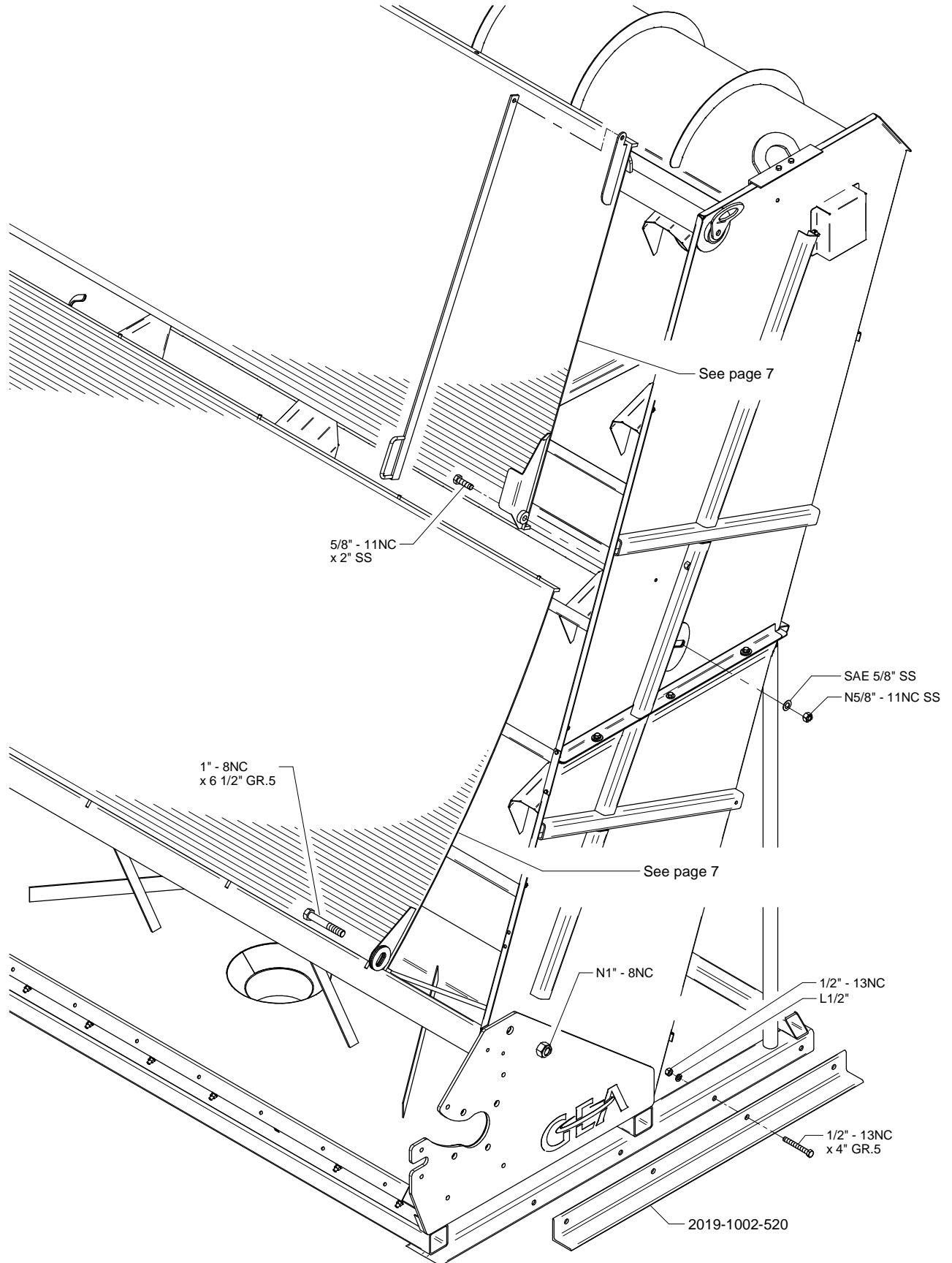

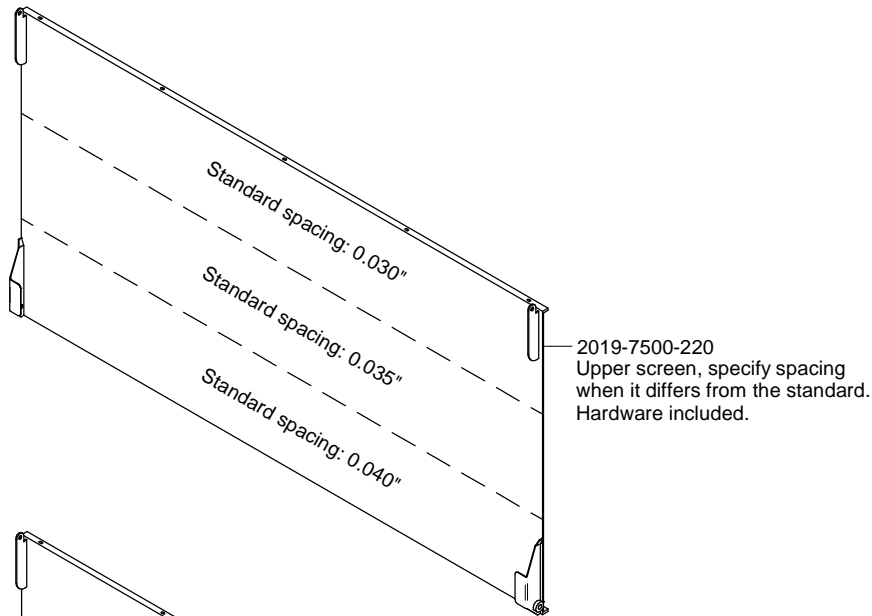

2019-7500-220  
Upper screen, specify spacing when it differs from the standard.  
Hardware included.

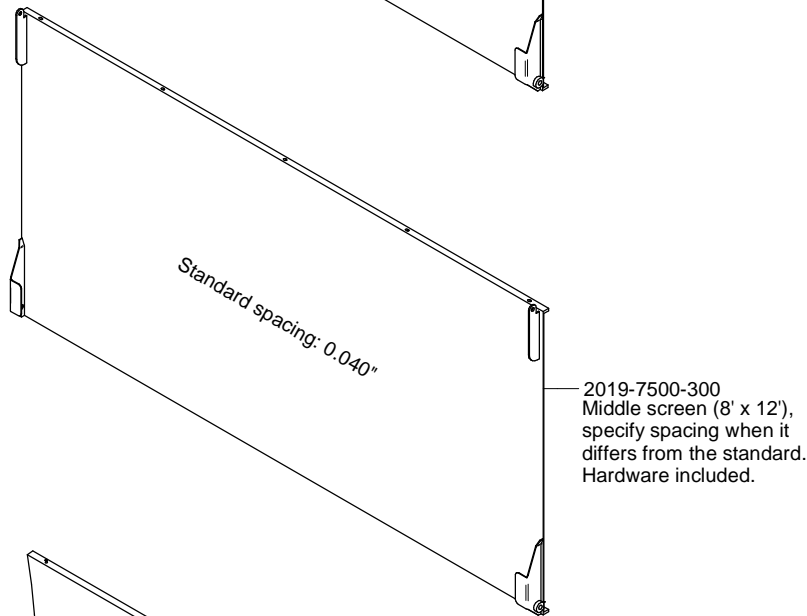

2019-7500-300  
Middle screen (8' x 12'), specify spacing when it differs from the standard.  
Hardware included.

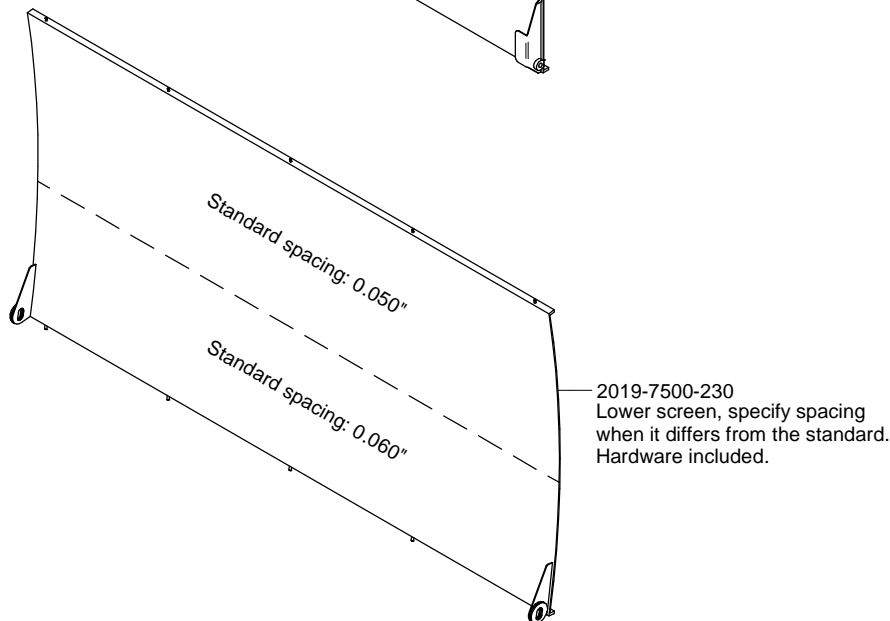

2019-7500-230  
Lower screen, specify spacing when it differs from the standard.  
Hardware included.

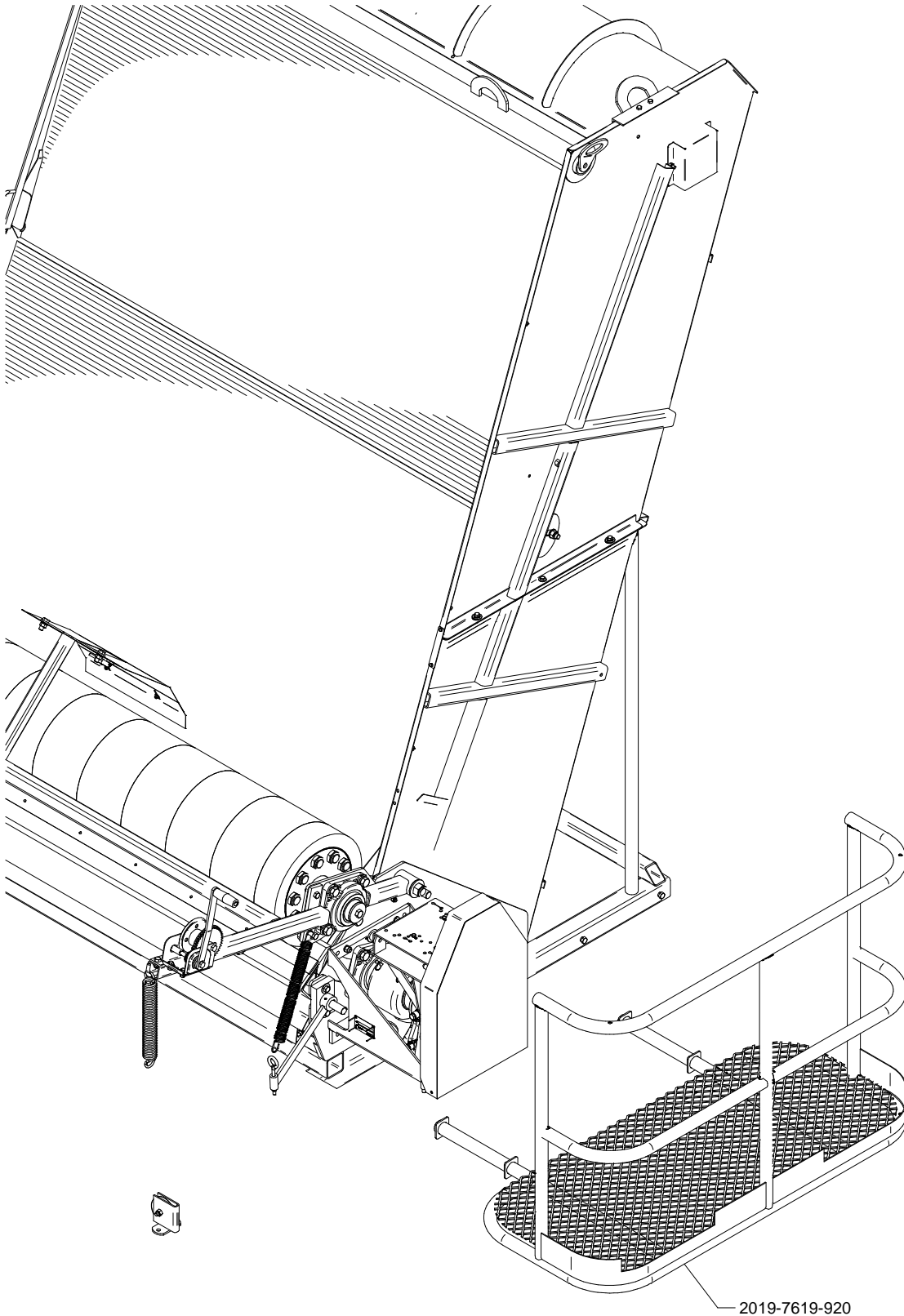



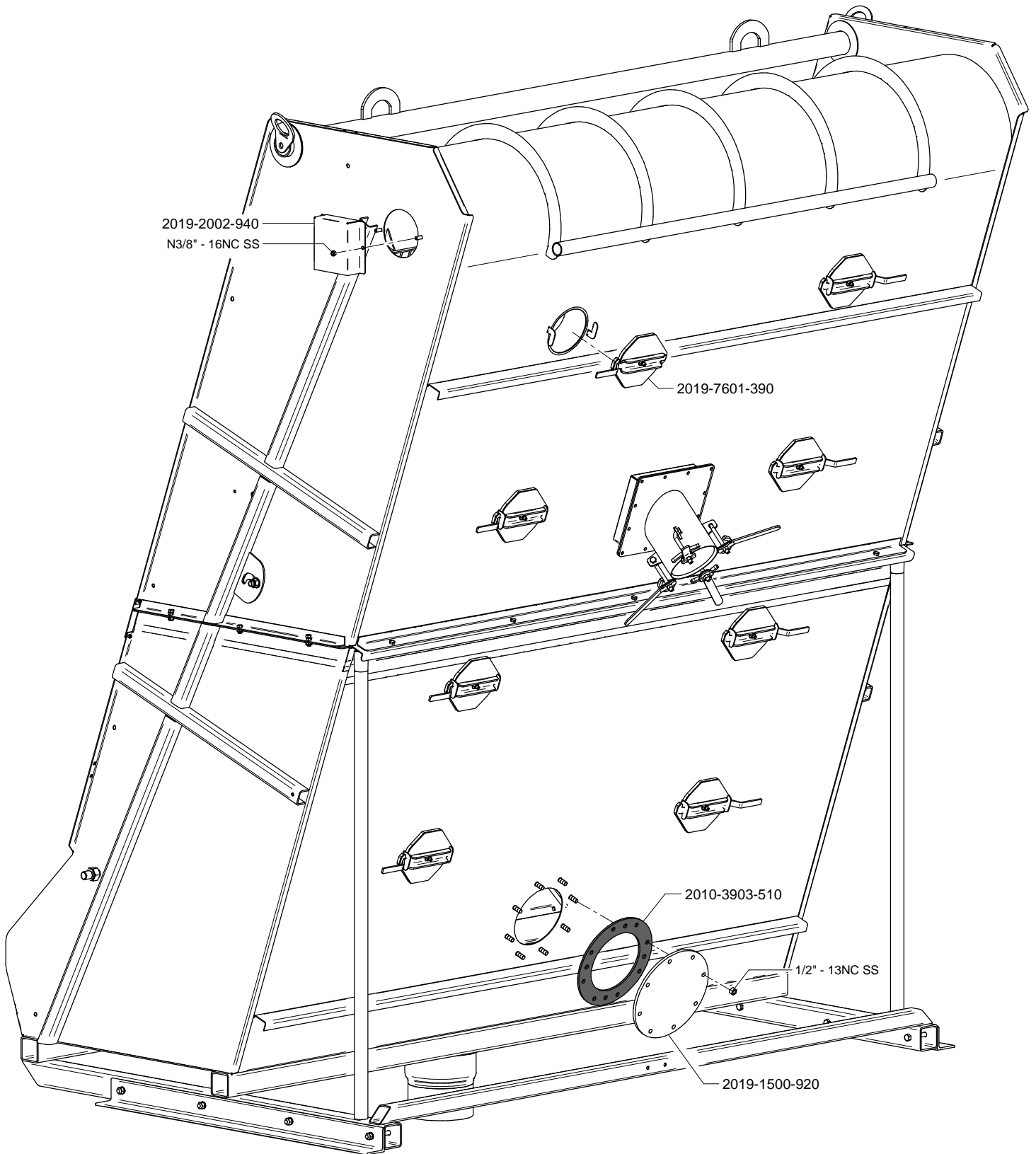

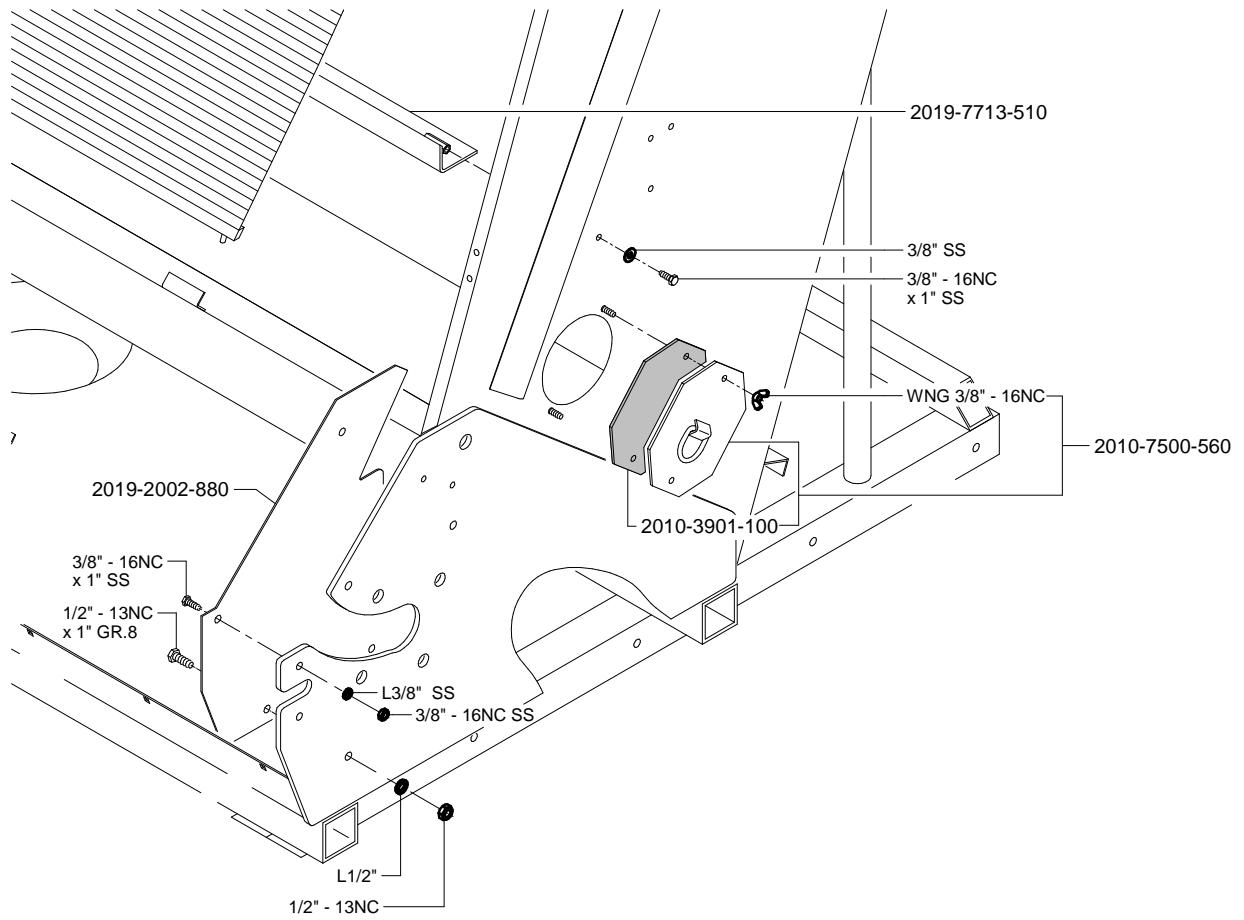

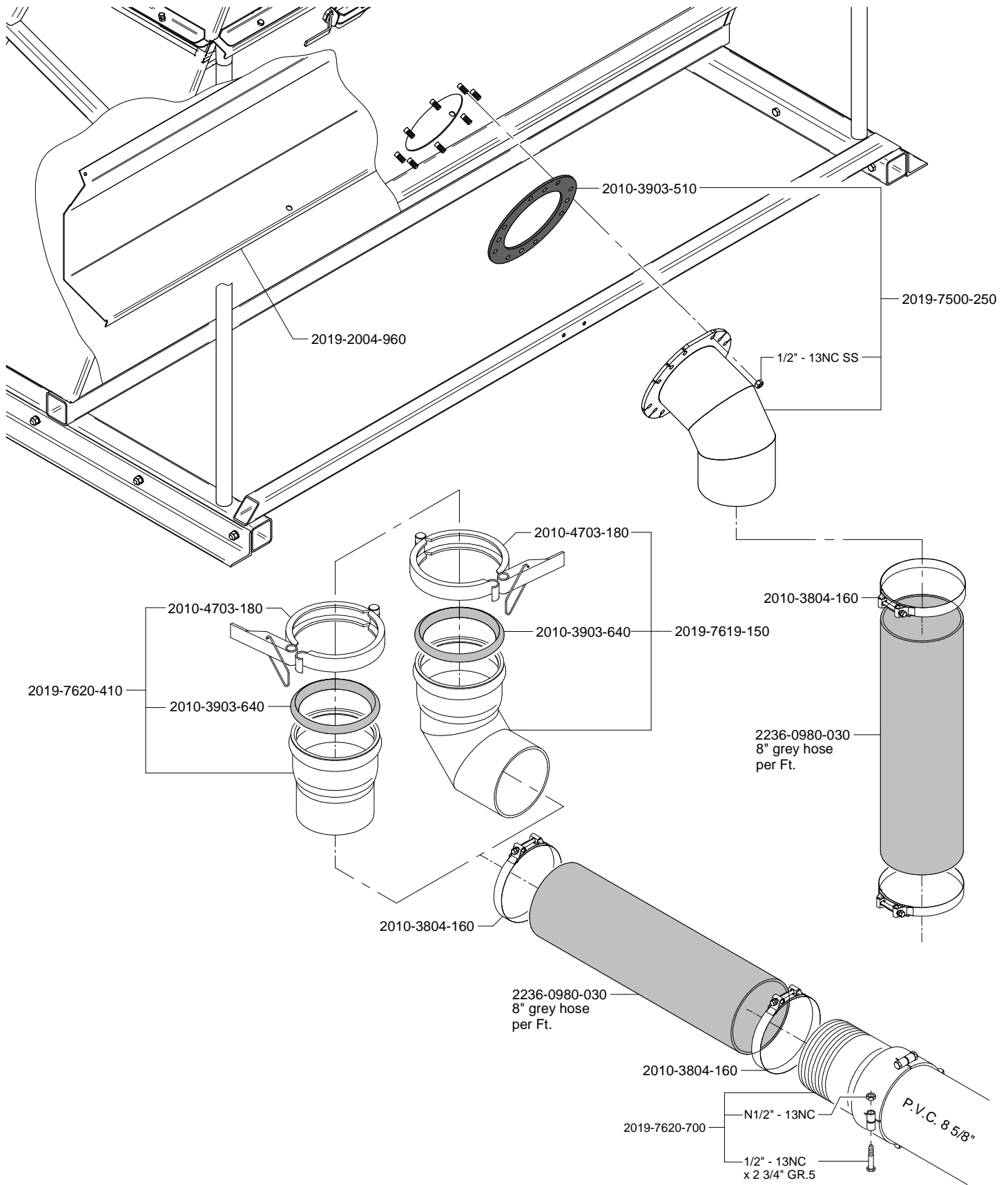

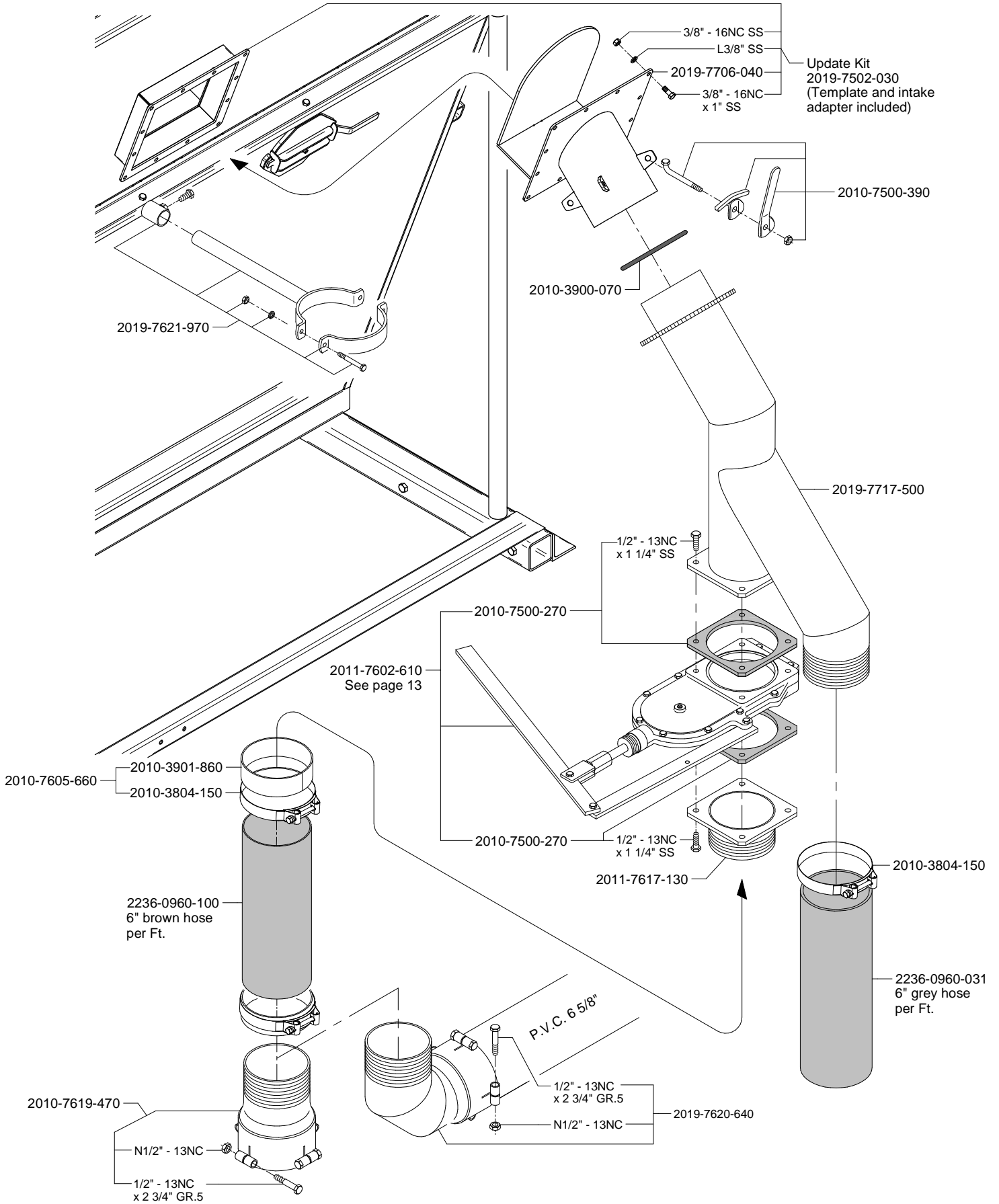

Complete cast iron gate valve  
2011-7602-610

